

Chale

H182/P02
INSTRUCTION MANUAL

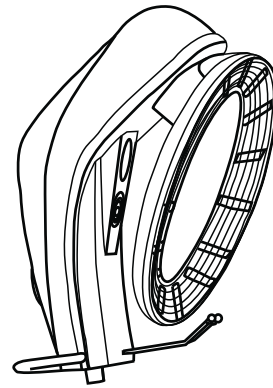

EN

CONTENTS

Product Information	1
Part Instruction	2
Assembly Instructions	3
Control Panel	10
Cautions	11
Operation Order	13
Modes-Application & Reference Work State	15

Please read the operation manual before using the product.

Please put the operation manual in the place easy for you to read and you can read it at any time.

Product Name: P02
Product Code: H182

Chale hair processor features the infrared temperature test module to test hair temperature. Our product can test temperature of hair instantly and precisely without damaging hair.

WARRANTY

The warranty period is one year. DIR warrants to you, the original buyer, that goods shall be free of defects in material and/or workmanship attributable to manufacture for one year from date of buyer's receipt of product. Damage resulting from improper handling after merchandise is received, or from exposure to weather or extreme atmospheric conditions is not covered by the warranty.

For any other information please contact our support team:

DIR BIRMINGHAM	DIR LONDON	DIR NEW YORK	DIR COLOGNE	DIR IRELAND	DIR CHINA
66 Rea Street South Birmingham B5 6LB UK ----- Tel: +44(0)121 6434777 ----- Email: sales@dirgroup.co.uk	Unit 1 River Road Business Park 33 River Road, Barking Greater London IG11 0DA UK ----- Tel: +44(0)20 8591 9310 ----- Email: sales.london@dirgroup.co.uk	24 Woodward Ave. Suite C Queens, NY 11385 USA ----- Tel: +1 (718)628-6668 +1 (800)728-2008 ----- Email: sales@dirsalonfurniture.com	Konrad-Adenauer-Straße 25 50996 Köln Germany ----- Tel: + 49 (0) 221 4678 0417 ----- Email: sales@dirgroup.de	Unit 5 Block E, Riverview Business Park, Nangor Road, Dublin 12 Republic of Ireland ----- Tel: +353 (01) 429 7969 ----- Email: sales.ireland@dirgroup.ie	广东伊众健康科技有限公司 Guangdong Yizhong technology co Ltd 地址： 广东顺德龙江龙峰大道38号 ----- 全国统一热线： +400 865 5603 ----- 邮箱： sales@dirchina.cn

Part Instruction

Product Name: Chale
Product Code: H182

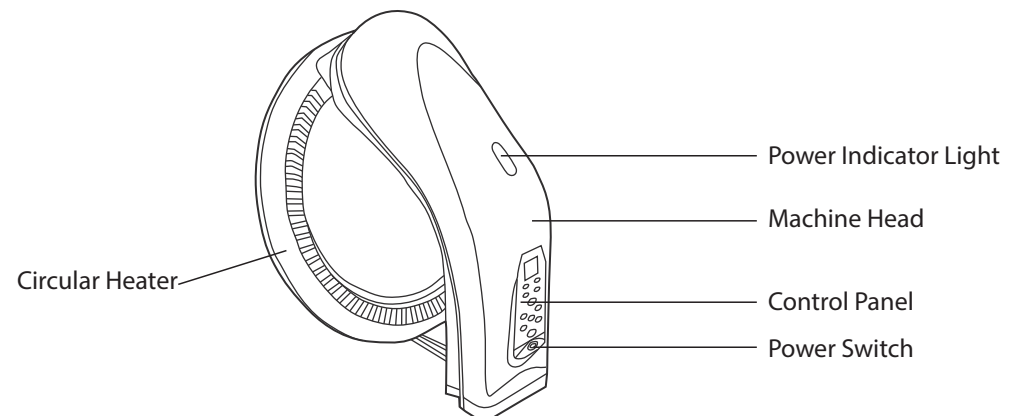
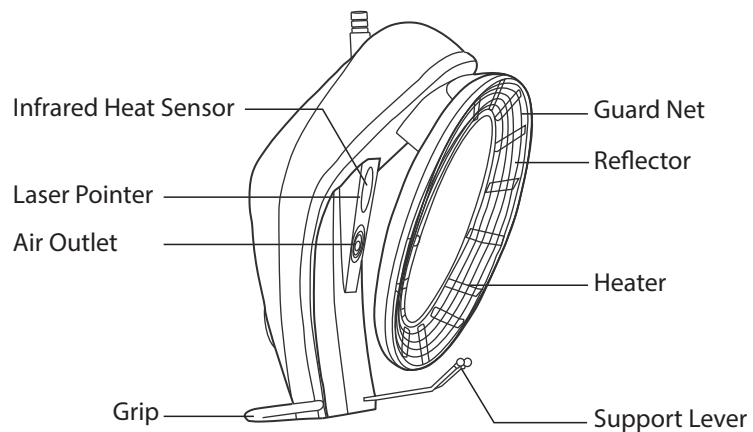
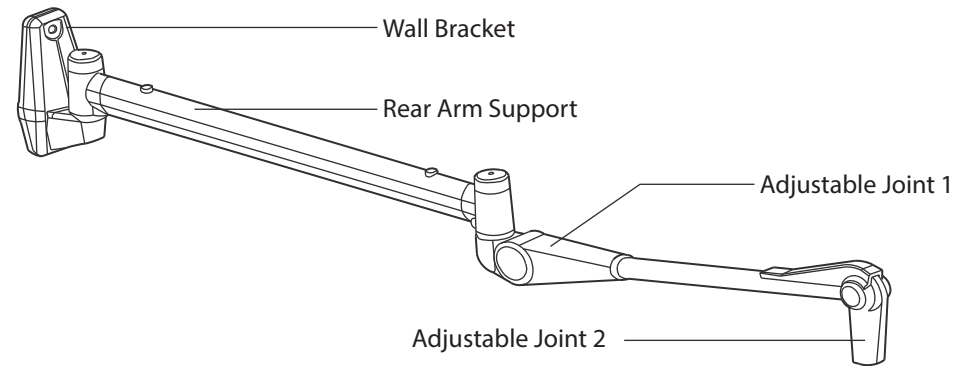

ASSEMBLY INSTRUCTIONS

Installation of Wall Mount Arm

Before Installation

1. Wall

The wall must be strong enough to support the arm assembly.

2. Height

The recommended height of the wall bracket is 1840/1950mm from the floor to the bottom of the bracket. (see diagram)

3. Electric Source

An electrical power outlet must be prepared on the wall within 500mm distance from the wall bracket.

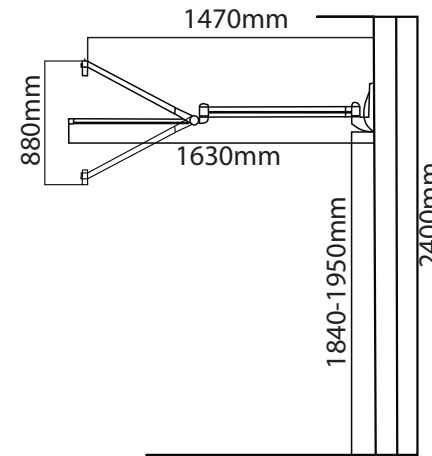

Installation of Wall Plate & Wall Bracket

1. The wall plate and wall bracket are already attached together with bolts upon delivery. (See diagrams)

2. With the supplied spanner, loosen the bolts and remove the wall plate

3. Use the wall plate as a template and drill three holes on the wall (please refer to diagram for the correct drill positioning). The size and depth of the holes will be in accordance with the bolts supplied.

4. Attach the wall bracket to the wall with the bolts, and then fix with the supplied washers.

5. Attach the wall bracket to the wall plate, and then tighten with bolts.

Caution! As the wall plate and wall bracket are subject to a large load, please make sure that the wall plate is installed correctly and securely.

To remove the wall mount, a spanner would have been supplied, please unscrew the bolts and remove from the wall with care.

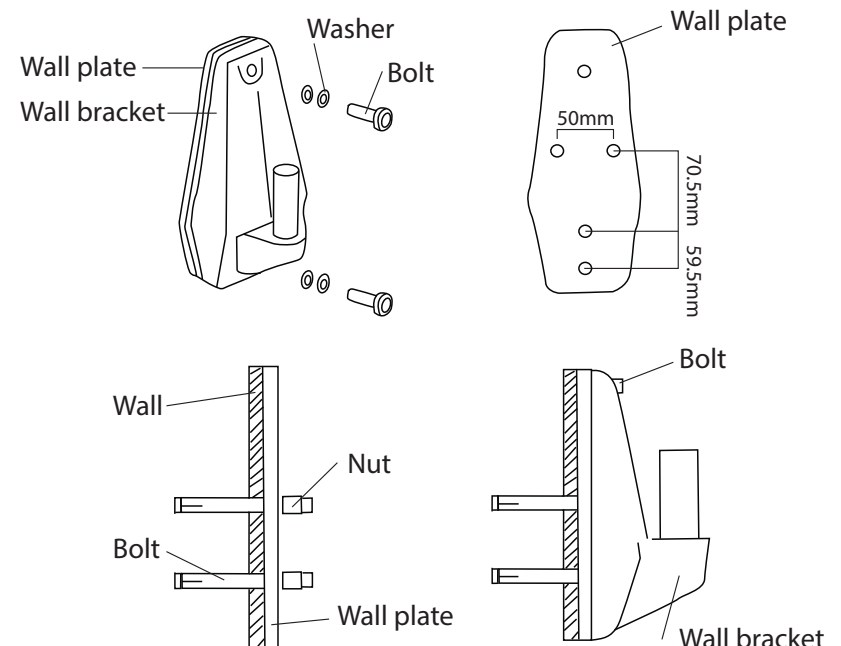

ASSEMBLY INSTRUCTIONS

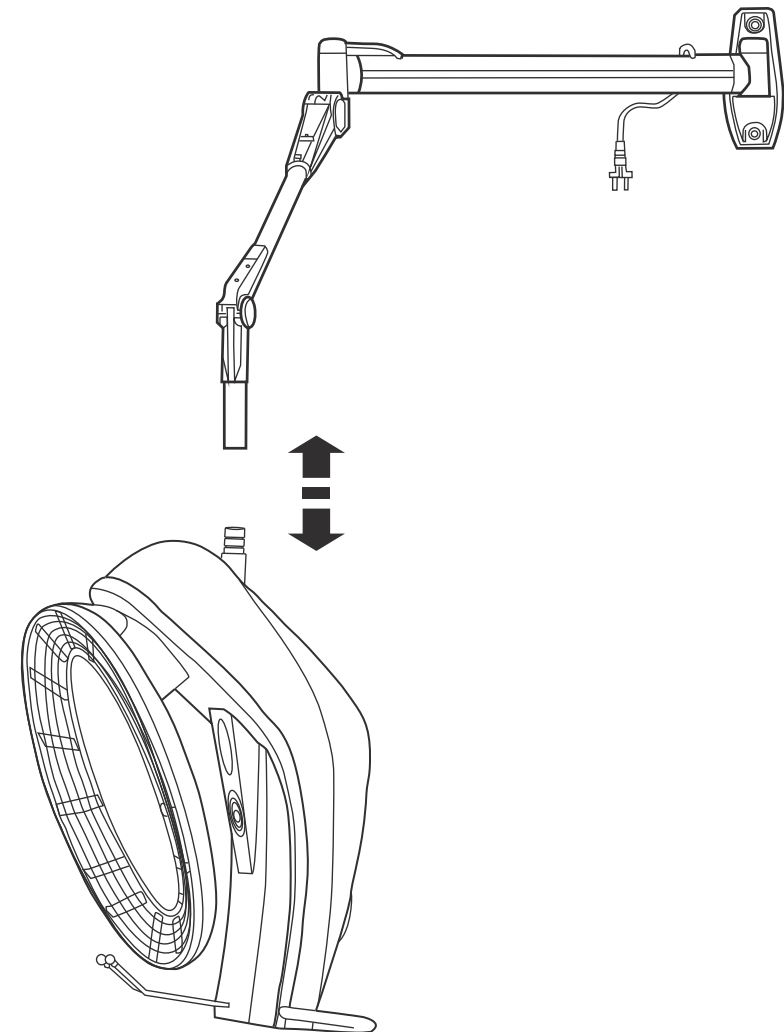
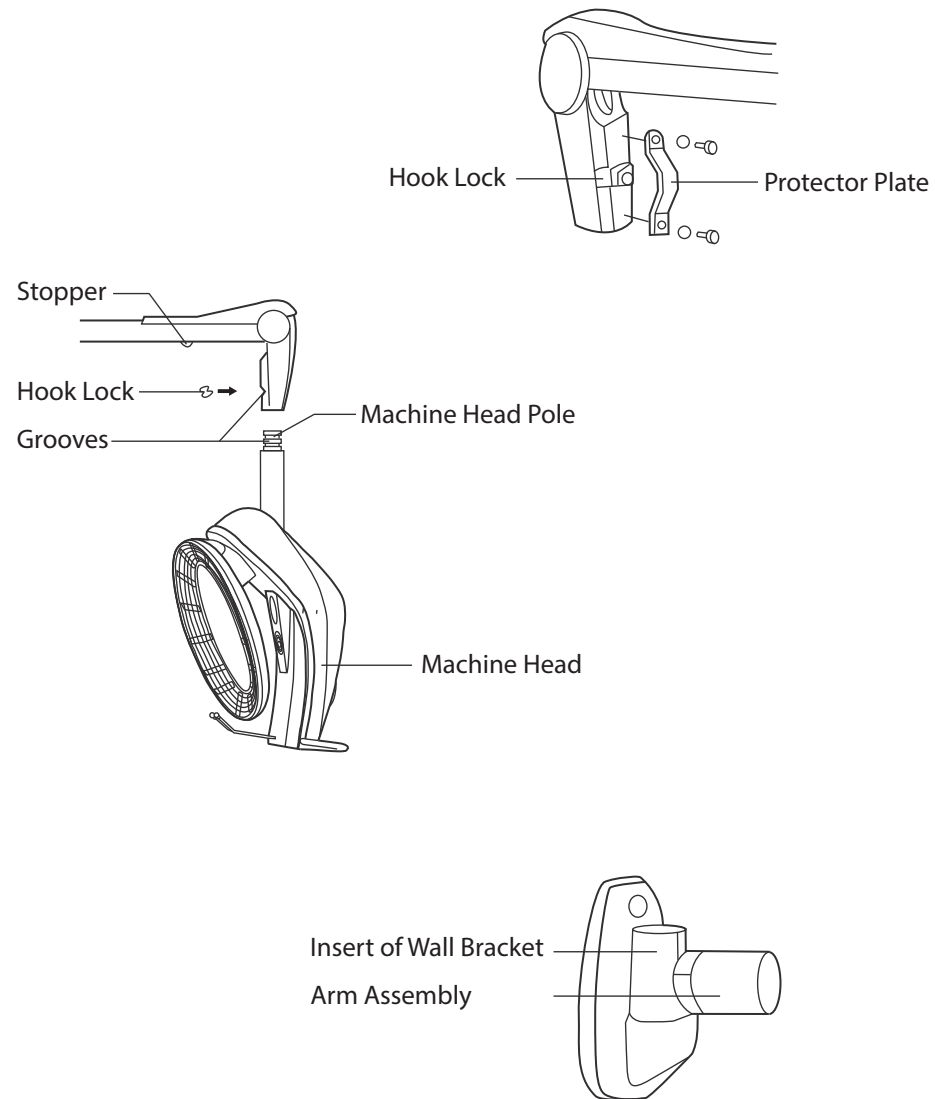

ASSEMBLY INSTRUCTIONS

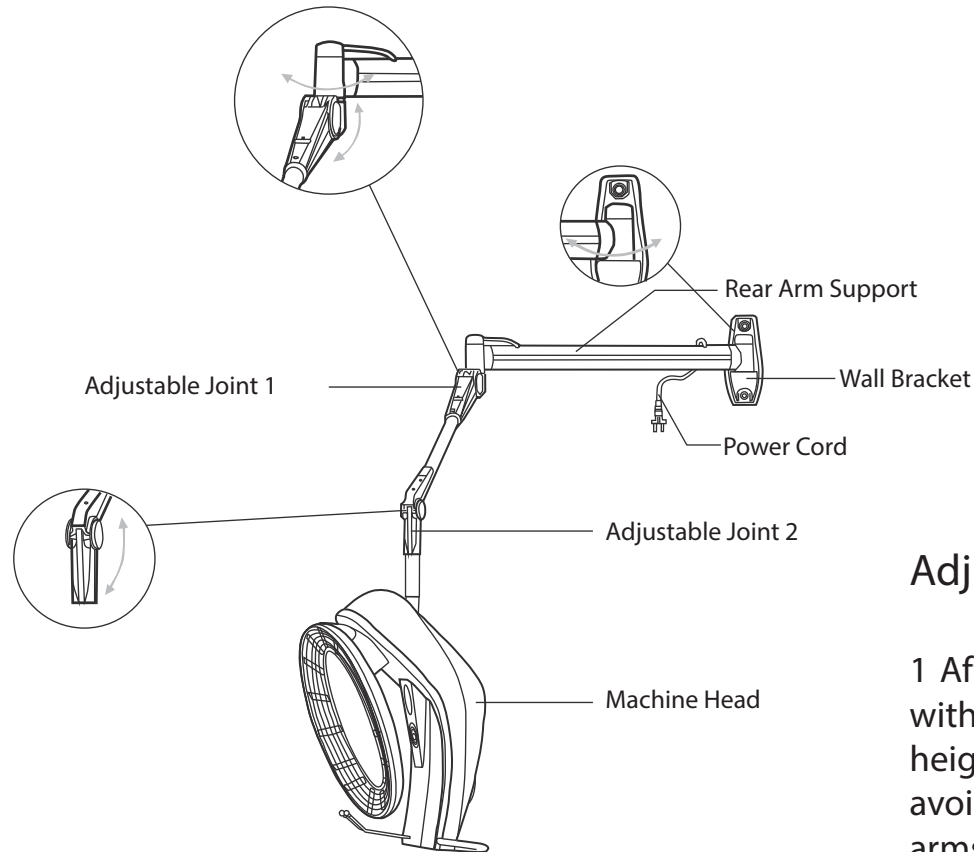

Adjustment of Arm Assembly

1 After finishing the installation, hold the machine body with two hands and move up and down to adjust the height position as you require. Please operate with care avoiding ceilings, furniture etc. In order to protect the arms, it is suggested not to remove the cover off the arms and not to rotate the adjusting bolt.

2 Before the manufacturer delivers the product the strength of the arm spring has been adjusted. Please load the correct weight as shown on the arm assembly.

Correct Positioning

Adjust the height of the Chale hair processor by moving the inner sliding pipe of the wall mount up and down, set the distance from the rotating point to the head at about 12cm and 12cm to the front point of the infrared sensor. The distance between the neck and the support lever is roughly 5cm. Pressing the Infrared Orientation Indicator Key will make the infrared eradicate the centre of the customers head.

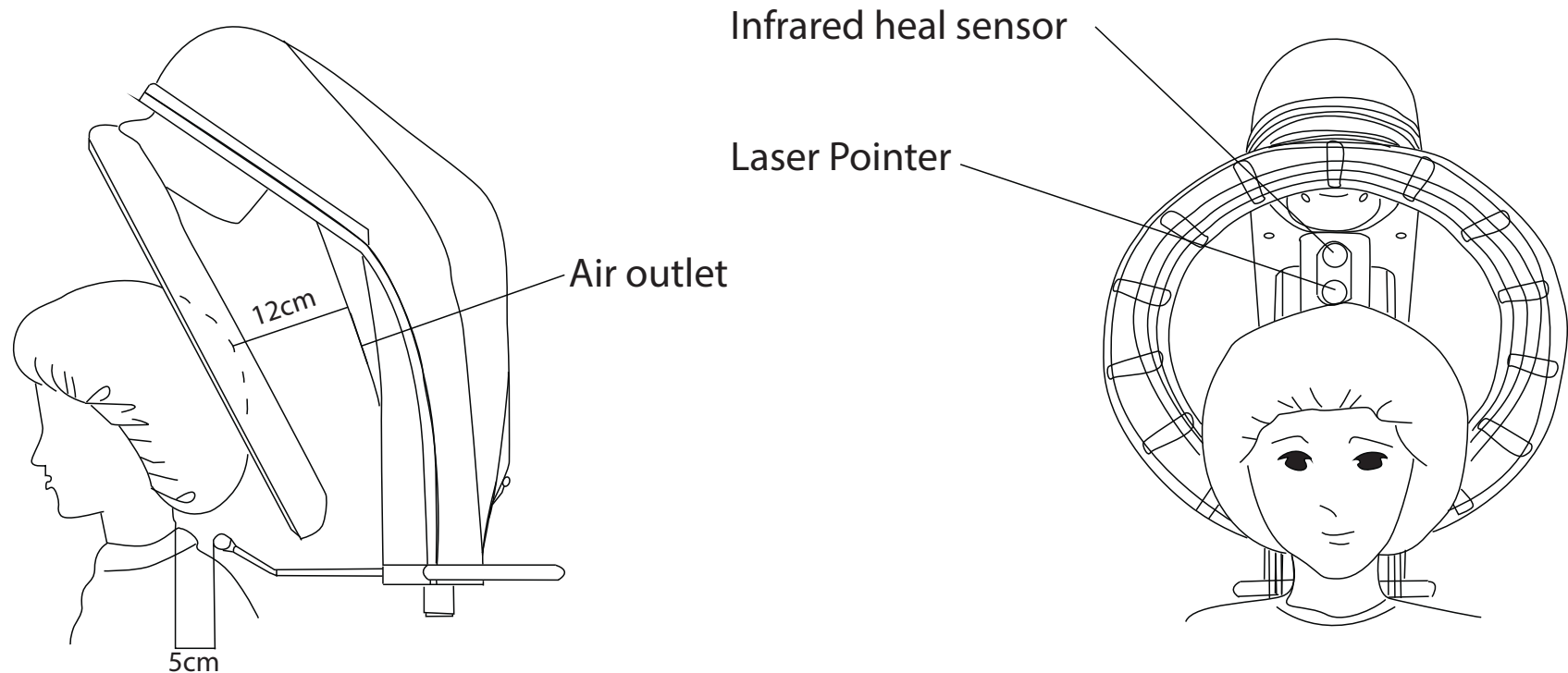

Control panel

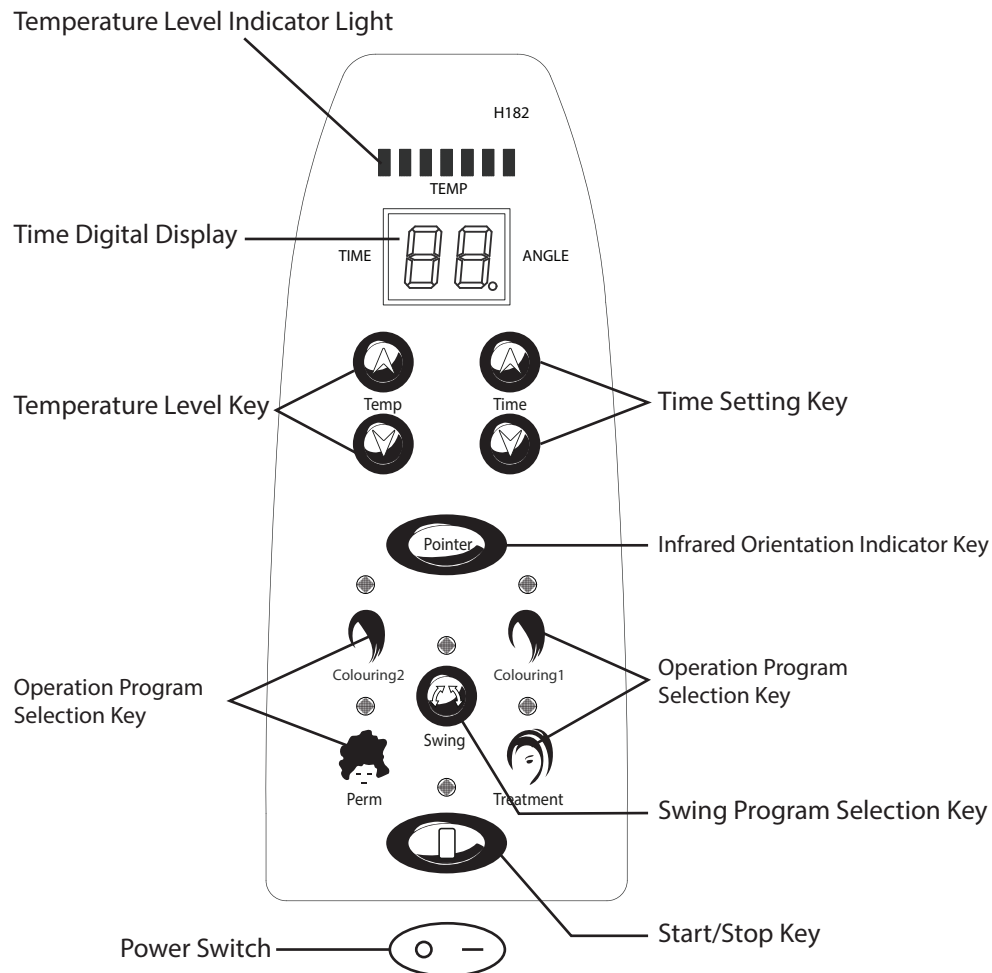

1. Temperature Level Indicator Light

The chart below shows the various temperature settings. There are 7 levels in total.

Level 1	Level 2	Level 3	Level 4	Level 5	Level 6	Level 7
40C	45C	50C	55C	60C	65C	70C

2. Time Digital Display

It shows the working time.

It can also display the angle if you press the Swing Program Selection Key, it will show the angle from 180 – 40.

3. Temperature Level Key

Pressing this key can change the temperature levels.

4. Time Setting Key

Pressing this key can change the setting time. Pressing up or down once can lengthen or shorten time by 1 minute. By holding the key you can lengthen or shorten time by 5 minutes.

5. Infrared Orientation Indicator Key

The Infrared temperature test position is irradiated for 10 seconds. It can use to be the orientation standard after confirmation.

6. Operation Program Selection Key

For different requirements, different programs are available. During operation time and temperature can be changed at your will.

7. Swing Program Selection Key

If you don't need the infrared convoluting or if you want to swing at different angles, you can press this key. If you press this key twice the angle can be adjusted at your will.

8. Start/Stop Key

Press this key to start every program. Once you have finished the treatment please key stop after every cycle.

9. Power Switch

The main power switch: Press - to turn on or Press O to turn off.

Cautions

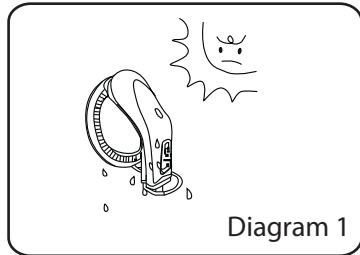

1. Please avoid exposing and working the machine at extreme hot, cold or damp conditions. It is best to use this machine between 10c – 25c.

2. Please connect the machine with a sustainable outlet and do not share with other appliances.

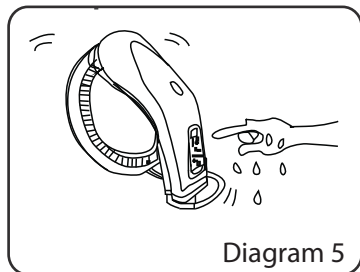
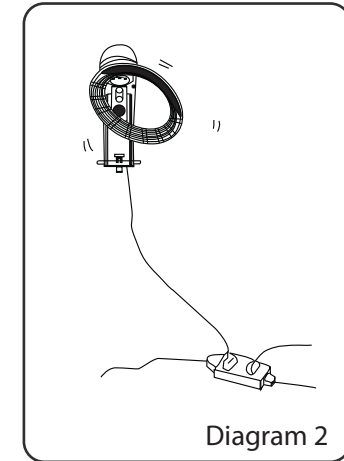

5. Do not get the machine wet or hang any wet/damp towels on the circular heater. Do please keep the machine dry at all times.

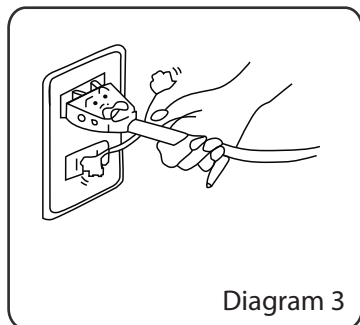

3. Do not disconnect the power plug by pulling the cable. Hold the plug and then pull.

4. Do not move the machine by pulling the power cord or garbing the circular heater.

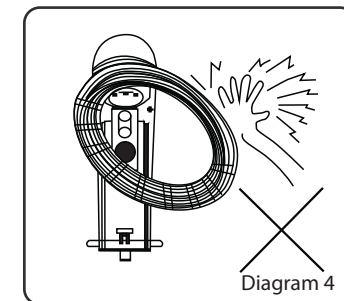

Cautions

6. Do not insert or metal objects into the machine, otherwise you may get a short circuit or an electric shock.
7. The infrared does not have any bad effects on the human body; however, if any customers feel unwell or any discomfort caused by the temperature, than please stop the machine immediately.
8. If the machine causes any malfunction, please contact the technical support team as soon as possible. Do not attempt to repair yourself.
9. If the power cord has any damage, to avoid danger, please contact the technical support team.
10. Please keep children away from the machine at all times when in operation

Operation Order

1. Set the machine at the correct position.

If the circular heater is not at the correct position then the hair processor will not perform at its optimum performance.

2. Turn on the Power Switch

After one minute of turning on the power, the temperature indicator light and the time digital display will illuminate

3. Select a Program

Choose different programs according to the customer's requirements.

The program selected will illuminate and the setting time and temperature will also be shown.

After starting and during the operation, the time and temperature can be altered.

4. Start/Stop Key

After starting, press this key, the circular heater starts rotation and all indicators will illuminate; including the indicator light, power indicator and the selected program light.

During operation, press this key, the circular heater will stop heating and rotation immediately.

5. During Operation

During operation the time digital display shows the remaining time. The radix point will coruscate at a frequency of one second alternation

During operation, the time and temperature can be alternated.

Press the Start/Stop key to stop operation, you can change to another program and begin next treatment.

6. Time Up

When the treatment time is over, the timer will show as "0" the electronic beep will sound and it will stop heating; however, the circular heater will take a little longer to come to a full stop, after two minutes of cooling time the machine will sound again and the circular heater will stop rotation.

7. Turn off the Power Switch After Finishing Work

ASSEMBLY INSTRUCTIONS

Swing Operation

1. Adjust Position

■Chale can be adjusted freely so it won't be too close to the customers head or in the way of the user.

2. Swing Selection

■After turning on the power, press the Swing Program Selection Key to confirm the set temperature and time press this key again and the time display will be alternated to show the rotation angle.

3. The Setting Alteration of Time, Temperature & Angle

■According to the customers' hair and the type of lotion, alternate the time, temperature and angle

■Using the Time Setting Key to alternate the time and using the Temperature Level Adjusting Key to alternate the temperature

■Using the Time Setting Key to alternate the angle by pressing the \triangle ∇ keys.

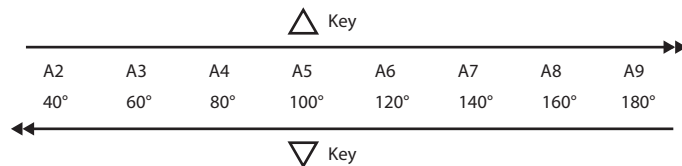

How to Set Program at Your Will

After you press the Operation Program Selection Key, the standard fixed value can be alternated. Then turn off the power, the newly set value will be saved in memory.

1. Select the program to be reset.
2. Alternate the time setting and temperature.
3. Then press the Operation Program Selection Key and hold for 3 seconds, the electronic chime will sound, the indicator light will illuminate and the optional settings are set.
4. When your hand moves away from Operation Program Selection Key, all the settings will be complete.
5. Restart the power switch and confirm whether the program has been set at your specifications.

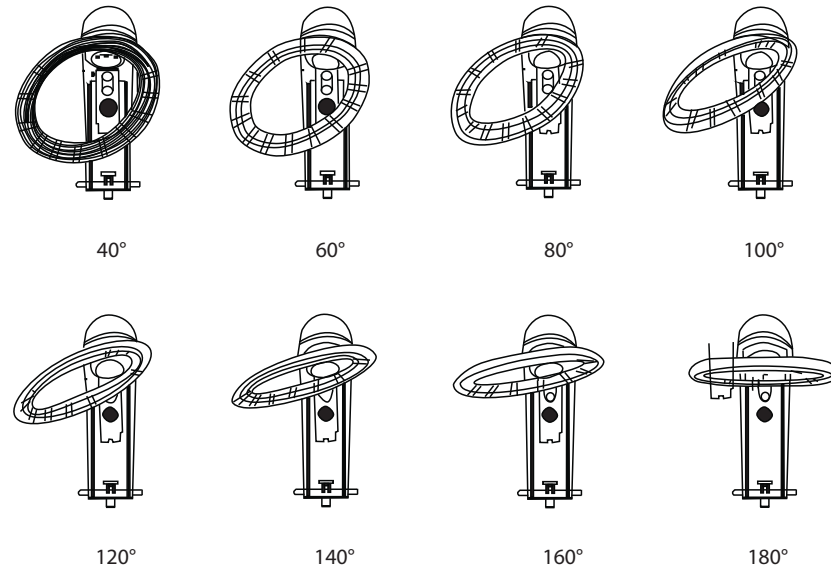

Modes-Application & Reference Work State

Both the temperature and time in the following table are the value fixed before leaving factory.

Operation Modes	Application	Time	Temperature	Angle	Temperature Control Way
Colouring 1	Adjust time and temperature to suit to type of dye, quality of hair.	10 mins	50°C	Rotation	Infrared computer control
		Rondom setting		— —	
Colouring 2	Adjust time and temperature to suit to type of dye, quality of hair.	10 mins	55°C	Rotation	
		Rondom setting		— —	
Perm	It is used for heating perm lotion. Adjust time and temperature to suit to the hair condition.	10 mins	50°C	Rotation	
		Rondom setting		— —	
Treatment	Adjust time and temperature to suit to type of shampoo and quality of customer's hair.	10 mins	55°C	Rotation	
		Rondom setting		— —	
Swing	Do partial adjustment when colouring and perm.	10 mins	55°C	Angle swing	Operating by programmed time controlling
		Rondom setting			

N.B.

1. Computerised infrared rays can ensure the temperature of customers' hair is always controlled at the set temperature.
2. After operation is finished, the circular heater will stop heating up and slow down rotation for 2 minutes.
3. After a program is finished, the machine will cool down for 2 minutes.

ASSEMBLY INSTRUCTIONS

GUARANTEE CARD

MODEL: H182
Serial NO:
DATE OF PURCHASE:
CONTACT PERSON:
CONTACT TELEPHONE:
CONTACT ADDRESS:
REPAIR ITEM:

DATE:

GUARANTEE CARD

Dear customer,

Dir[®]

Thank you for using our products. Ensuring you are pleased and assured to use our products, please fill in the GUARANTEE CARD carefully when you buy our products. From the date of purchase, you will have 12 months of free repair after-sales service due to quality problem, but not due to man-made damage.

Special attention! When selling the goods, customers and distributors shall fill in the guarantee card, giving the Serial No, and sales date. After confirmation by both parties, customers will have this free repair after-sales service.

MODEL: H010	DATE OF PURCHASE:
Serial NO:	
CONTACT PERSON:	
CONTACT TELEPHONE:	
CONTACT ADDRESS:	

DATE	PROBLEMS CAUSE	REPAIR DATE	REPAIRMAN SIGNATURE

CONTACT US

DIR BIRMINGHAM (HEADQUATERS)

66 Rea Street South
Birmingham
B5 6LB
UK
Sales: +44(0)800 085 3667
Customer Service: +44(0)121 6433877
Fax: +44(0)121 6333291
Email: sales@dirgroup.co.uk
Website: www.dirsalonfurniture.uk

DIR LONDON

Unit 1 River Road Business Park
33 River Road, Barking
Greater London IG11 0DA
UK
Sales: +44(0)20 8591 9310
Fax: +44(0)20 8594 4147
Email: sales.london@dirgroup.co.uk
Website: www.dirsalonfurniture.uk

DIR NEW YORK

24 Woodward Ave.
Suite C
Queens, NY 11385
USA
Sales: +1 (718)628-6668
+1 (800)728-2008
Fax: +1 855-628-5168
Email: sales@dirsalonfurniture.com
Website: www.dirsalonfurniture.com

DIR COLOGNE

Konrad-Adenauer-Straße 25
50996 Köln
Germany
Sales: + 49 (0) 221 / 88888.128
Fax: + 49 (0) 221 / 88888.122
Email: sales@dirgroup.de
Website: www.dirgroup.de

DIR IRELAND

Unit 5 Block E
Riverview Business Park
Nangor Road
Dublin 12
Republic of Ireland
Sales: +353 (01) 429 7969
Email: sales.ireland@dirgroup.ie
Website: www.dirgroup.ie

DIR CHINA

广东伊众健康科技有限公司
Guangdong Yizhong technology co Ltd
广东顺德龙江龙峰大道38号
全国统一热线：
+400 865 5603
邮箱: sales@dirchina.cn
官网：www.dirchina.cn

If you have any enquires regarding the product warranty, please contact our customer services team.

www.dirsalonfurniture.uk