

ALNATT

8111

INSTRUCTION MANUAL

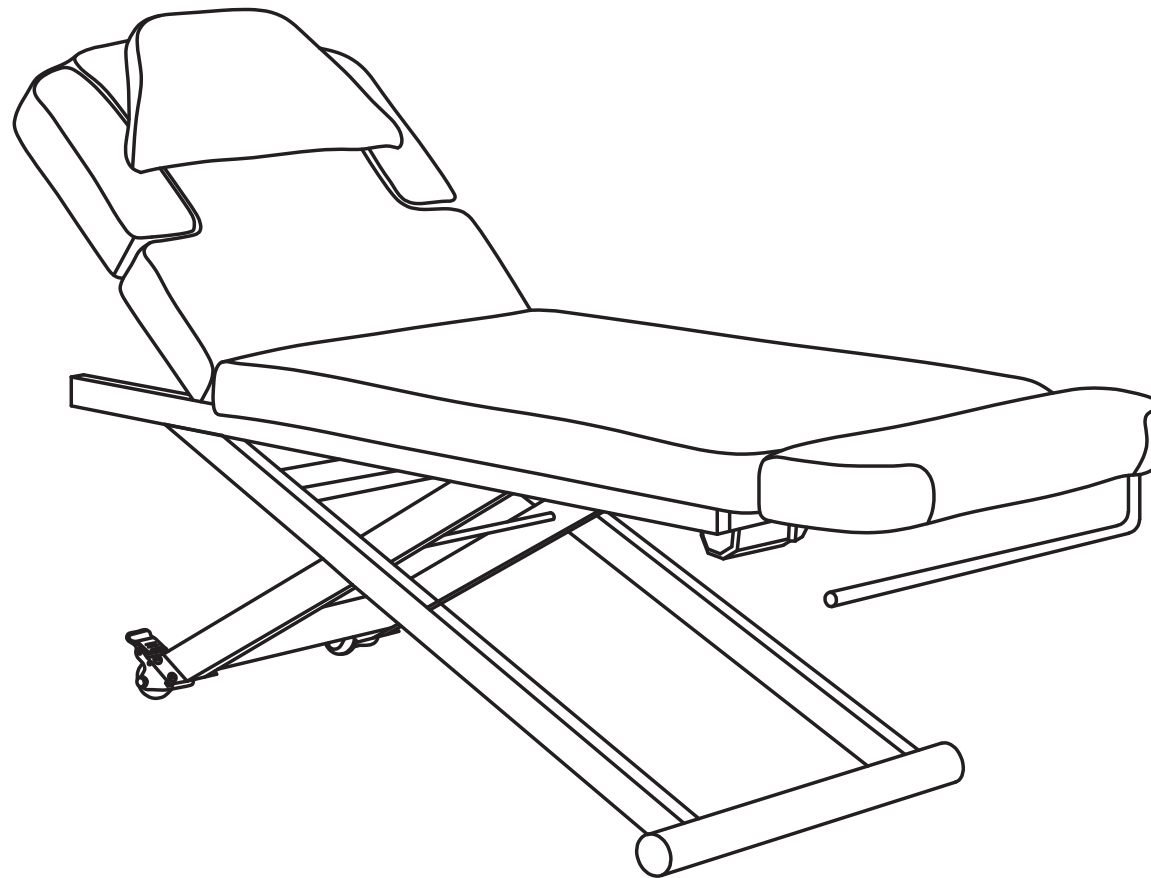

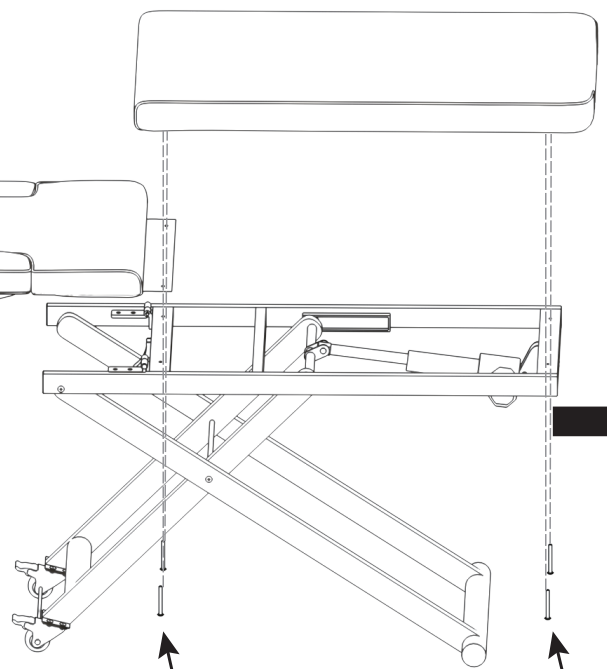
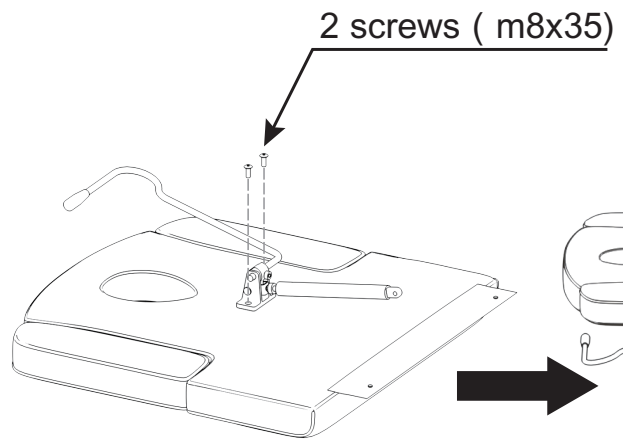

2 screws (m8x50)

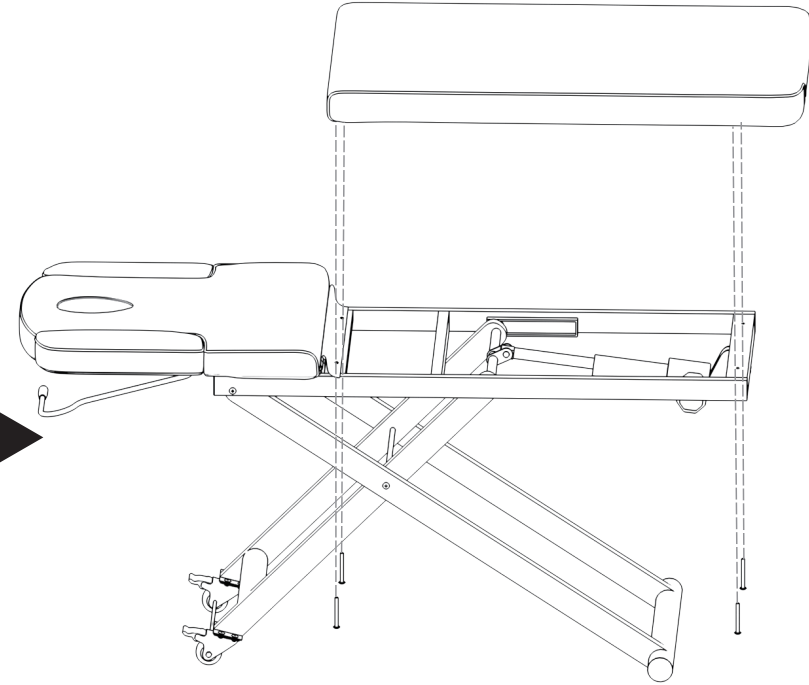

2 screws (m8x70)

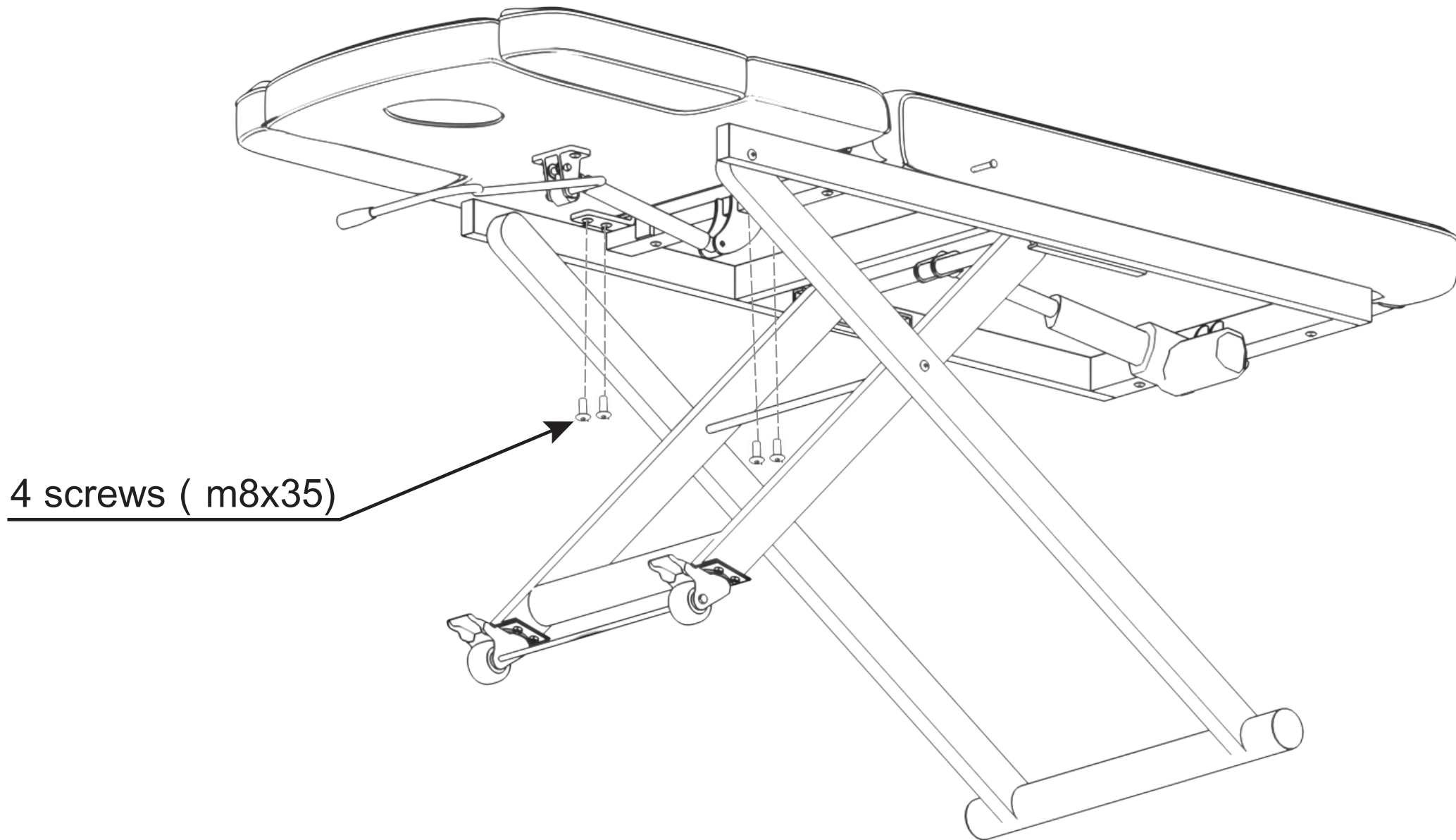

4 screws (m8x35)

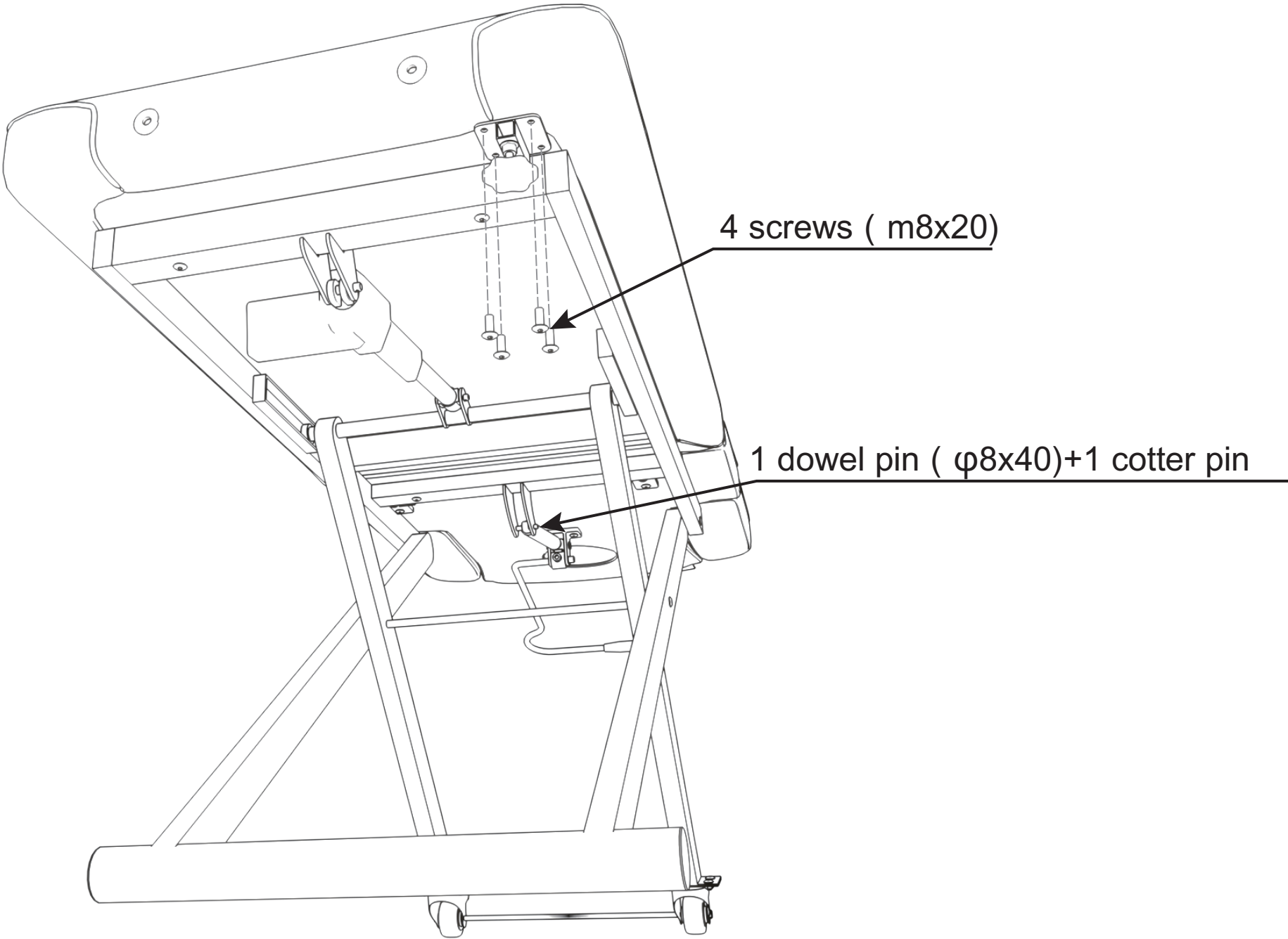

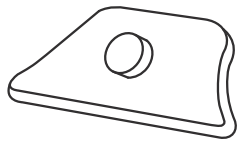

Headrest is removable

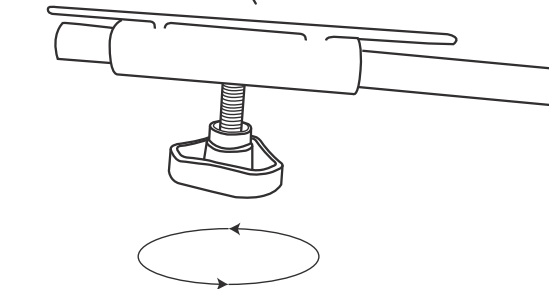
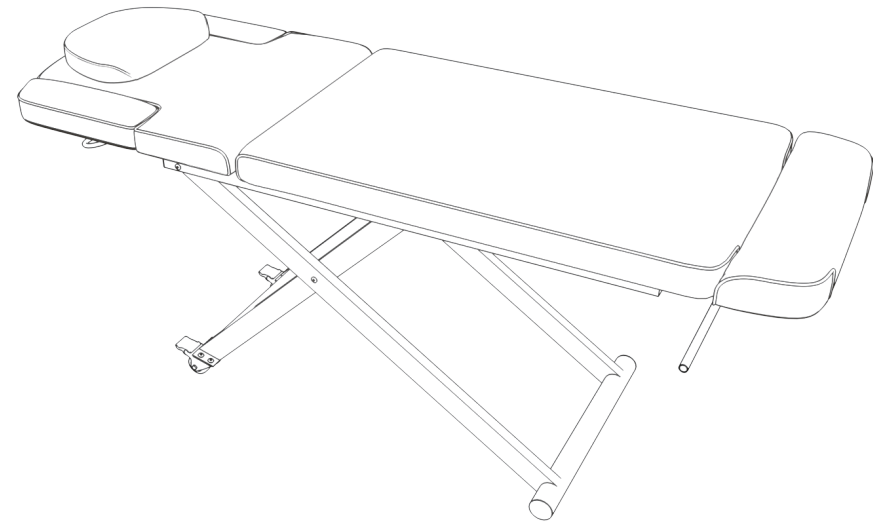
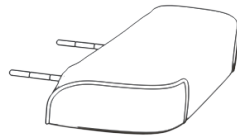
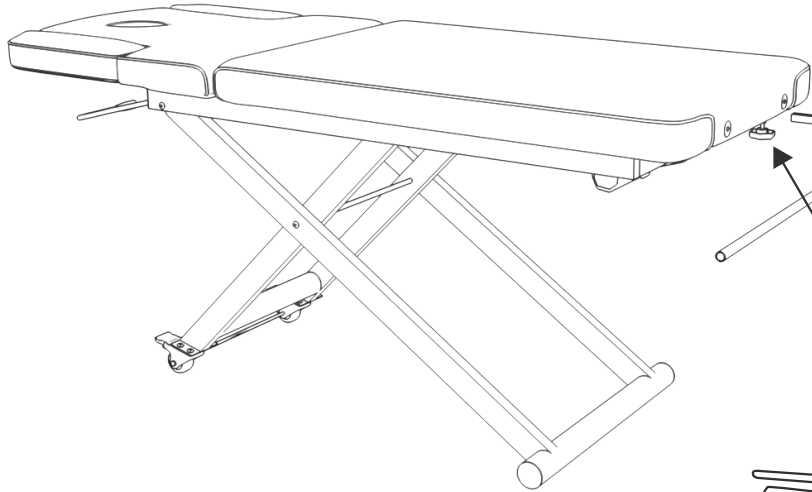
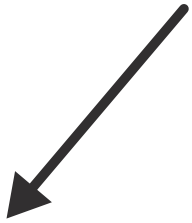

To adjust tissue roll holder: tighten/loosen bolt

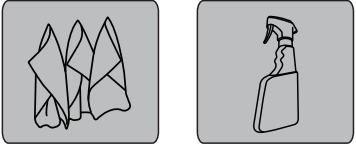

Wipe clean with a cloth dampened in a mild leather cleaner.
Wipe dry with a clean cloth.

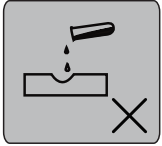

Avoid the use of abrasives, bleaches or solvents.

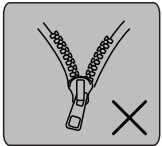

Never remove and wash faux leather covers.

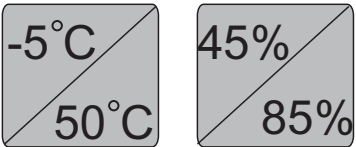

Storage and using environment

Please do not place this product under strong light or in moist environment, to avoid the damage on product. It can be used in the temperature of $-5^{\circ}\text{C}\sim 50^{\circ}\text{C}$ and humidity of $45\%\sim 85\%$



If you meet problems while using this product, please try the given solutions.

Problems	Causes	Solutions
When press the remote control, The bed doesn' t move.	1. Electrical plug is not inserted well. 2. Transformer links to each plug which is not inserted well.	1. Pull out plug and insert it again. 2. Pull out the transformer plug under the bed and insert it again.
When clients use the bed, the bed shakes or makes noise.	Screws come loose.	Tighten each screw.

If there is still a problem after trying the solution given in this troubleshooting guide, please stop using the product and contact our customer service team on +44(0)121 643 3877

Product care



Brush away excess hair

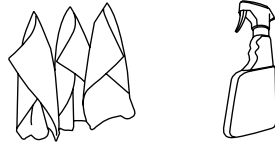

Clean surface with damp cloth or use simple soap & water solution.

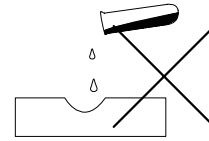

Avoid using corrosive cleaning agents such as bleaches.

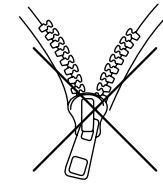

Do not remove upholstery for cleaning

Warranty

The warranty period is one year. DIR warrants to you, the original buyer, that goods shall be free of defects in material and/or workmanship attributable to manufacture for one year from date of receipt of product. Damage resulting from improper handling after merchandise is received, or from exposure to weather or extreme atmospheric conditions is not covered by the warranty. For any other information please contact our support team:

DIR BIRMINGHAM

66 Rea Street South
Birmingham
B5 6LB
UK

Tel:
+44(0)121 6434777

Email:
dirsalon@gmail.com

DIR LONDON

Unit 1 River Road
Business Park
33 River Road, Barking
Greater London
IG11 0DA
UK

Tel:
+44(0)20 8591 9310

Email:
dirsalon@gmail.com

DIR NEW YORK

575 Underhill Blvd.
Suite 170
Syosset, NY 11791
USA

Tel:
+1 (718)628-6668
+1 (800)728-2008

Email:
sales@dirsalonfurniture.com

DIR IRELAND

Unit 20, Goldenbridge Ind.
Estate Tyrconnell Road
Inchicore
Dublin 8
Republic of Ireland

Phone:
+353 (1) 429 7969

Email:
sales.ireland@dirgroup.ie